

# INTERTECH PUMPS

Engineering That Ignites

## 4RB-F

### AVAILABLE MOUNTING CONFIGURATIONS

4RB-F FRAME MOUNT  
4RB-RP-F REDI-PRIME FRAME MOUNT  
4RB-EM ENGINE MOUNT  
4RB-RP-EM REDI-PRIME ENGINE MOUNT  
4RB-VF VERTICAL FRAME MOUNT  
4RB-VC VERTICAL COUPLED

### OPERATING LEVELS

MIN FLOW	175 GPM	39.7 m <sup>3</sup> /h
MAX FLOW	1600 GPM	363 m <sup>3</sup> /h
DISCHARGE SIZE	4"	102 mm
SUCTION SIZE	6"	152 mm
SOLIDS HANDLING	0.84"	21.34 mm
MAX SPEED	3000 RPM	3000 RPM
SHUT-OFF HEAD	500'	152 m
MAX WORKING PRESSURE	175 PSI	1207 kPa
BEP HEAD	285'	87 m
BEP FLOW	1470 GPM	334 m <sup>3</sup> /h
BEP PERCENT	85%	85%

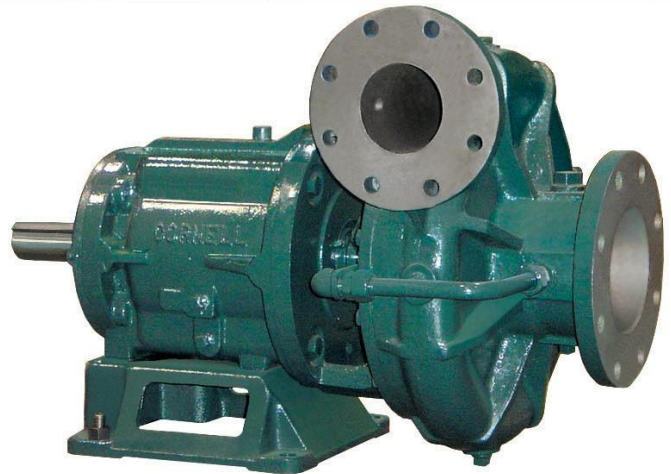

A typical picture of the pump is shown. Please contact Aquarius Pump Company for further details. All information is approximate and for general guidance only.

The 4RB general purpose pump is designed with Aquarius's renowned quality and durability. It features a 4" discharge and a 6" suction, enclosed multi-vane impeller and flanged tangential single volute. The pump end mounts to F5, F16, EM5, EM16, VC5, VC16, VF5, and VF16

bearing frames. Optional Redi-Prime or Venturi Prime priming system is available. Bearings are heavy-duty, grease lubricated, single ball bearings with a minimum of 20,000 hours bearing life.

- External hydraulic balance line
- Back pullout design
- Replaceable hub & suction wear rings
- Replaceable shaft sleeve
- High efficiency hydraulics
- Low operating costs
- Modular bearing frame
- Long B-10 bearing life (20,000 hour minimum)
- Two year warranty
- Optional Cycloseal® with type 1 mechanical seal
- Optional Run-Dry™ lubrication system
- Grease lubrication standard - oil lubrication optional
- SAE #3, 4 & 5 engine mount available to fit
- Oversized shaft and bearings

PARTS	STANDARD MATERIAL (CAST IRON BRONZE FITTED)
WEAR RINGS	Bronze SAE 660
IMPELLER	Bronze SAE 40
VOLUTE	Cast Iron ASTM A48 CL30
SHAFT	SAE 1144 Stressproof Steel
SHAFT SLEEVE	Bronze SAE 660
BACKPLATE	Cast Iron ASTM A48 CL30
PACKING (STANDARD)	Graphited Acrylic
MECHANICAL SEAL (OPTIONAL)	Single T-1, Buna, Carbon/ Ceramic
BEARING FRAME	Cast Iron ASTM A48 CL30



AGRICULTURE



FOOD



INDUSTRIAL



MINING



MUNICIPAL



OIL & GAS



REFRIGERATION



RENTAL

# INTERTECH PUMPS

Engineering That Ignites

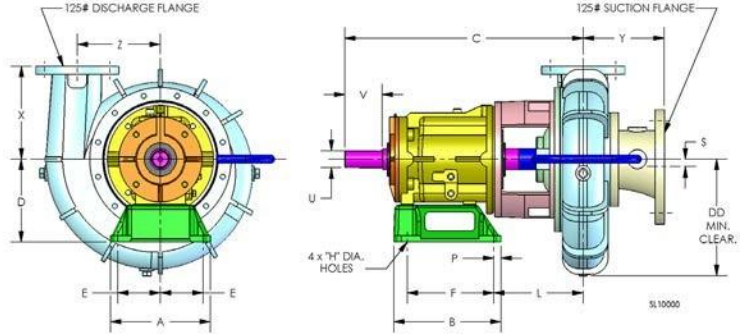
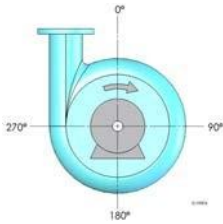

**NOTES:**

Discharge positions are viewed from the drive end.  
Standard increments of discharge position are shown in the chart below (DISCH INCR). Consult factory for other discharge positions.

PUMP DIMENSIONS																				
MODEL	FRAME	CONNECTION		DISCH. INC.	A	B	C	D	DD	E	F	H	L	P	U	V	X	Y	Z	KEYWAY
		DISCH.	SUCT.																	
4RB	F16	4	6	90°	12	12.88	25.75	9.75	11	5.12	10.38	0.81	7.9	0.88	2	4.5	10	7.38	8	.50X.25

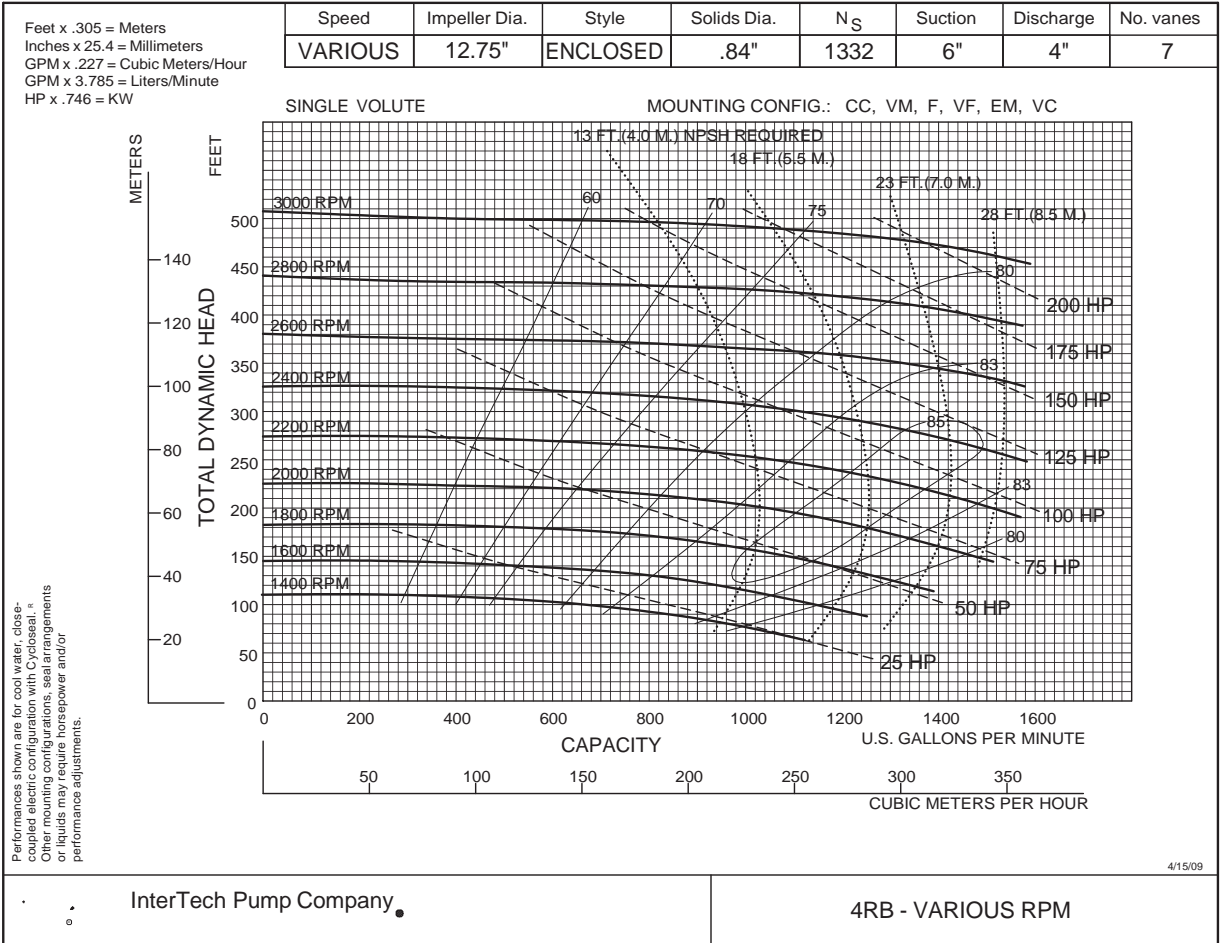

NEW PAGE

4RBVA