

INTERTECH PUMPS

Engineering That Ignites

3RB-F

AVAILABLE MOUNTING CONFIGURATIONS
3RB-F FRAME MOUNT
3RB-RP-F REDI-PRIME FRAME MOUNT
3RB-EM ENGINE MOUNT
3RB-RP-EM REDI-PRIME ENGINE MOUNT
3RB-VF VERTICAL FRAME MOUNT
3RB-VC VERTICAL COUPLED

OPERATING LEVELS		
MIN FLOW	75 GPM	17 m ³ /h
MAX FLOW	900 GPM	204 m ³ /h
DISCHARGE SIZE	3"	76.2 mm
SUCTION SIZE	5"	127 mm
SOLIDS HANDLING	0.5"	12.7 mm
MAX SPEED	2600 RPM	2600 RPM
SHUT-OFF HEAD	400'	122 m
MAX WORKING PRESSURE	175 PSI	1207 kPa
BEP HEAD	350'	107 m
BEP FLOW	800 GPM	182 m ³ /h
BEP PERCENT	79%	79%

PARTS	STANDARD MATERIAL (CAST IRON BRONZE FITTED, CI IMPELLER)
WEAR RINGS	Bronze SAE 660
IMPELLER	Cast Iron ASTM A48 CL30
VOLUTE	Cast Iron ASTM A48 CL30
SHAFT	SAE 1144 Stressproof Steel
SHAFT SLEEVE	Bronze SAE 660
BACKPLATE	Cast Iron ASTM A48 CL30
PACKING (STANDARD)	Graphited Acrylic
MECHANICAL SEAL (OPTIONAL)	Single T-1, Buna, Carbon/ Ceramic
BEARING FRAME	Cast Iron ASTM A48 CL30

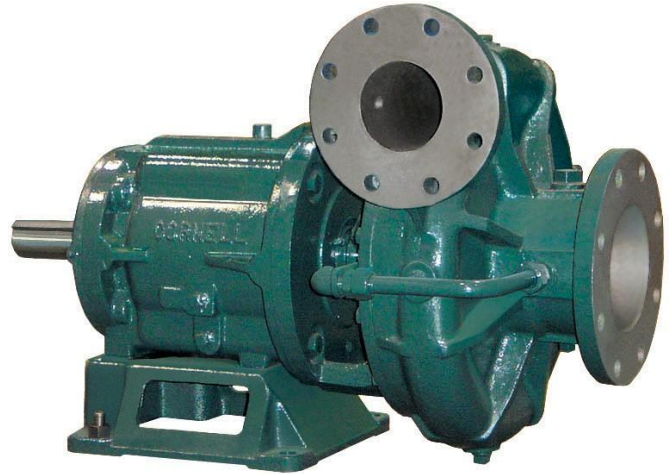

A typical picture of the pump is shown. Please contact InterTech Pump Company for further details. All information is approximate and for general guidance only.

The 3RB general purpose pump is designed with InterTech's renowned quality and durability. It features a 3" discharge and a 5" suction, enclosed multi-vane impeller and flanged tangential single volute. The pump end mounts to F5, F16, EM5, EM16, VC5, VC16, VF5, and VF16 bearing frames. Optional Redi-Prime or Venturi Prime priming system is available. Bearings are heavy-duty, grease lubricated, single ball bearings with a minimum of 20,000 hours bearing life.

- External hydraulic balance line
- Back pullout design
- Replaceable hub & suction wear rings
- Replaceable shaft sleeve
- High efficiency hydraulics
- Low operating costs
- Modular bearing frame
- Long B-10 bearing life (20,000 hour minimum)
- Two year warranty
- Optional Cycloseal® with type 1 mechanical seal
- Optional Run-Dry™ lubrication system
- Grease lubrication standard - oil lubrication optional
- SAE #3, 4 & 5 engine mount available to fit
- Oversized shaft and bearings



AGRICULTURE



FOOD



INDUSTRIAL



MINING



MUNICIPAL



OIL & GAS



REFRIGERATION



RENTAL

INTERTECH PUMPS

Engineering That Ignites

3RB-F

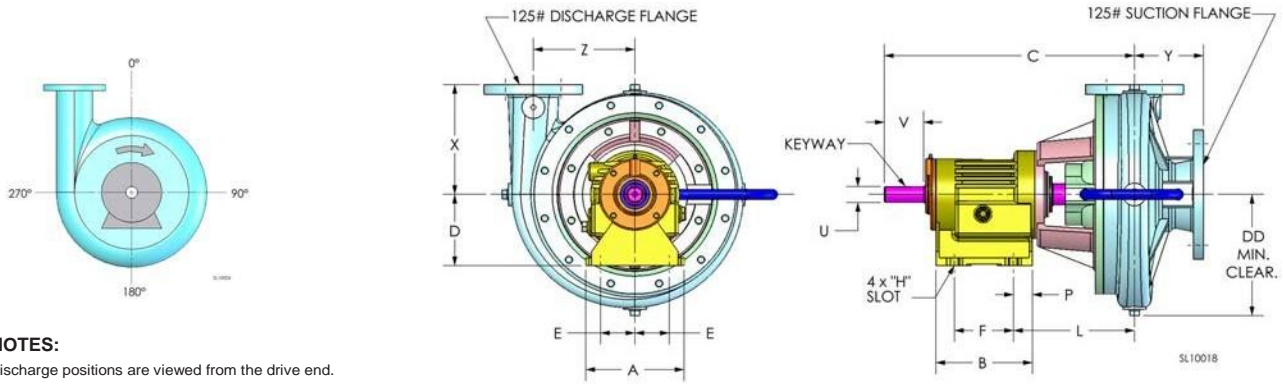

NOTES:

Discharge positions are viewed from the drive end.
Standard increments of discharge position are shown in the chart below (DISCH INCR). Consult factory for other discharge positions.

PUMP DIMENSIONS

MODEL	FRAME	CONNECTION		DISCH. INC.	A	B	C	D	DD	E	F	H	L	P	U	V	X	Y	Z	KEYWAY
		DISCH.	SUCT.																	
3RB	F5	3	5	90°	7.5	7.36	19.09	5.5	10	2.62	4.5	0.56	9.22	1.44	1.25	3	8.5	5.25	7.75	.25X.12

Feet x .305 = Meters
Inches x 25.4 = Millimeters
GPM x .227 = Cubic Meters/Hour
GPM x 3.785 = Liters/Minute
HP x .746 = KW

Speed	Impeller Dia.	Style	Solids Dia.	N _S	Suction	Discharge	No. vanes
VARIOUS	12.88"	ENCLOSED	.50"	918	5"	3"	7

SINGLE VOLUTE MOUNTING CONFIG.: CC, VM, F, VF, EM, VC

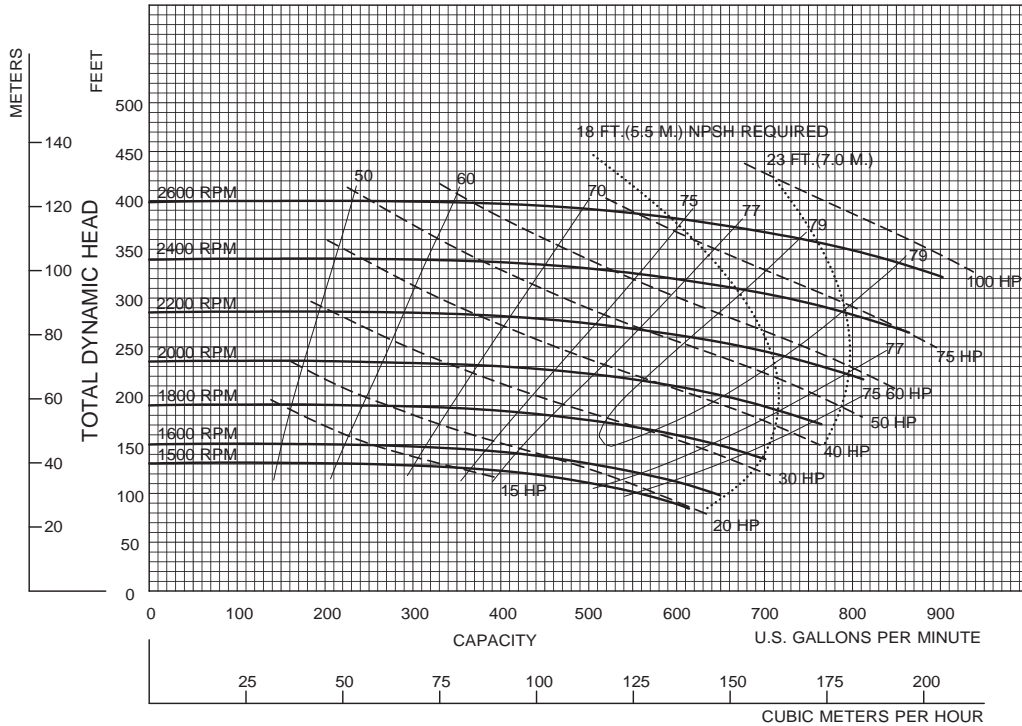

Performance shown are for each water, close control electric configurations with Cyclo Seal. Other mounting configurations, seal arrangements or liquids may require horsepower and/or performance adjustments.

SUPERSEDES 9/99

3RBVA

10/05/07

InterTech Pump Co.

3RB - VARIOUS RPM