

INTERTECH PUMP CO. 1WC Clear Liquid Pump

PUMP SPECIFICATION

Discharge Size - 1 inch

Suction Size - 1.5 inch

Mounting Configuration - horizontal or vertical
close coupled, horizontal frame and vertical
frame

Motor - TEFC standard (other motors available
on request)

Casing - cast iron ASTM A48, class 30

Impeller - silicon bronze ASTM C87500

Wear Rings - bronze SAE 660

Shaft Sleeve - bronze SAE 660

Shaft - (frame mount) SAE 1144 Stressproof®

Mechanical Seal - carbon-ceramic with buna
o-ring seat and stainless steel metal parts

Other materials available on request

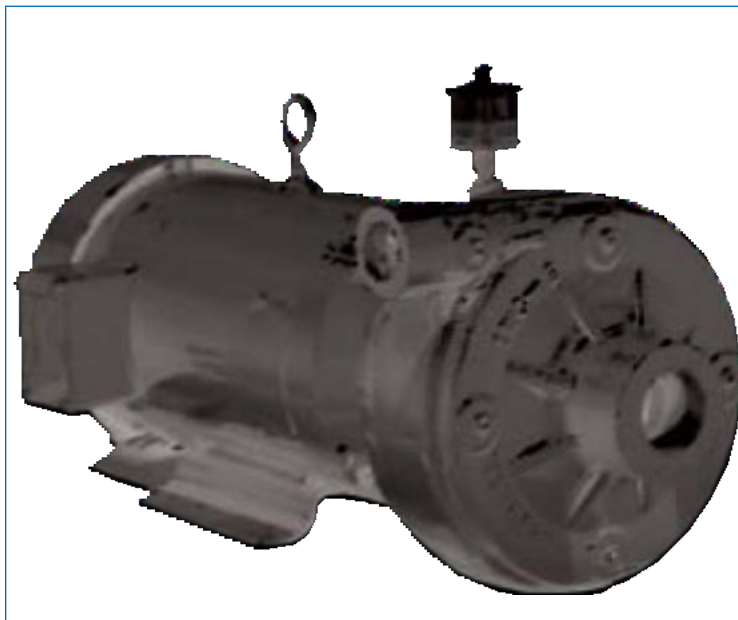

7.5 HP with optional run-dry feature shown

FEATURES & BENEFITS

- Ideally suited for water and water booster applications
- Back pull-out design
- T-21 single seal with run-dry option
- Heavy duty cast iron construction
- Patented Cycloseal® design (U.S. patent #5489187)
- Off the shelf availability in many motor sizes
- Two year warranty

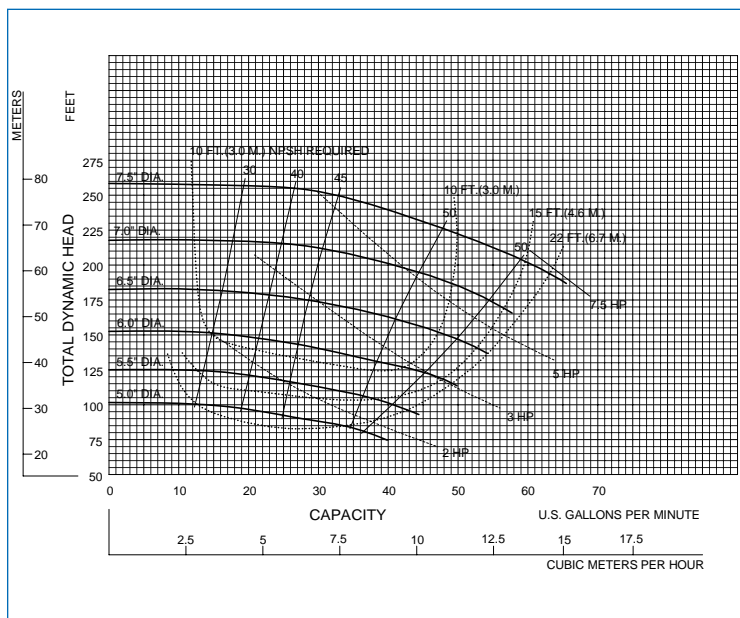

1WC - 3600 RPM

CLOSE COUPLED DIMENSIONS

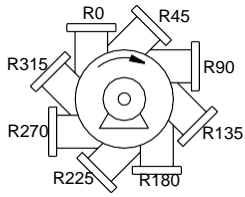

Discharge positions viewed from drive end-right hand

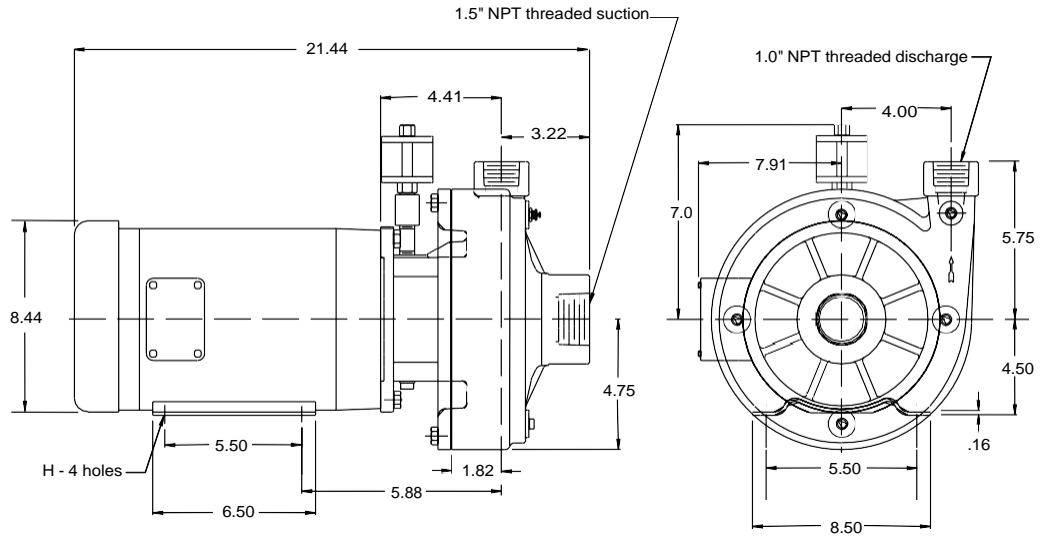

Do not use for construction unless certified.
Suction and discharge connection dimension can vary $\pm .12$ inch.

MOTOR DIMENSIONS

MOTOR SIZE	NEMA FRAME	A	B	D	E	F	G	H	O	R	AB	CP
1 HP (4 pole)	143JM	6.50	5.94	3.50	2.75	2.00	.12	.34	6.88	5.25	7.28	18.88
1.5 HP (4 pole), 2 HP, 3 HP (2 pole)	145JM	6.50	5.94	3.50	2.75	2.50	.12	.34	6.88	5.25	7.28	18.88
5 HP (2 pole)	184JM	8.50	6.50	4.50	3.75	2.75	.16	.41	8.44	5.88	7.91	21.44
7.5 HP (2 pole)	184JM	8.50	6.50	4.50	3.75	2.75	.16	.41	8.44	5.88	7.91	22.94

Motor dimensions are for standard efficiency TEFC motors and may vary depending on manufacturer.

F5 FRAME DIMENSIONS

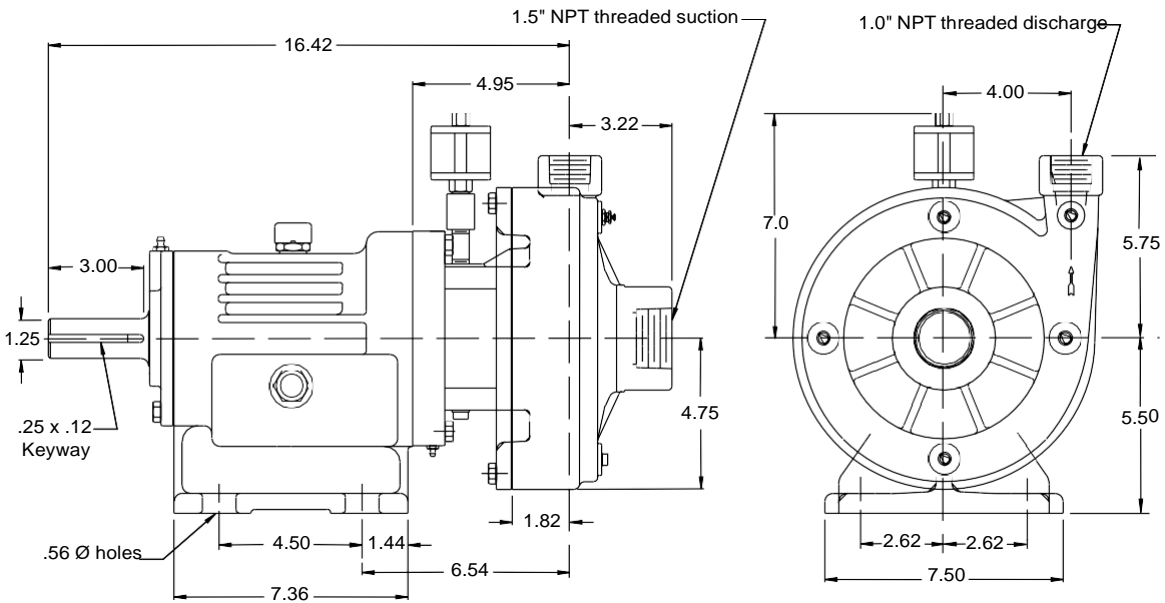

ISO9001 CERTIFIED