

INTERTECH PUMPS

Engineering That Ignites

10RB-F

AVAILABLE MOUNTING CONFIGURATIONS

10RB-F FRAME MOUNT
 10RB-RP-F FRAME MOUNT
 10RB-EM ENGINE MOUNT
 10RB-RP-EM ENGINE MOUNT
 10RB-VF VERTICAL FRAME MOUNT
 10RB-VC VERTICAL COUPLED

OPERATING LEVELS

MIN FLOW	2400 GPM	545 m ³ /h
MAX FLOW	7000 GPM	1589 m ³ /h
DISCHARGE SIZE	10"	254 mm
SUCTION SIZE	10"	254 mm
SOLIDS HANDLING	1.25"	32 mm
MAX SPEED	2200 RPM	2200 RPM
MAX WORKING PRESSURE	155 PSI	1069 kPa
SHUT-OFF HEAD	305'	93 m
BEP HEAD	205'	62.5 m
BEP FLOW	5900 GPM	1339 m ³ /h
BEP PERCENT	87%	87%



A typical picture of the pump is shown. Please contact InterTech Pump Company for further details. All information is approximate and for general guidance only.

The 10RB general purpose pump is designed with InterTech's renowned quality and durability. It features a 10" discharge and a 10" suction, enclosed multi-vane impeller and flanged tangential double volute.

Compatible with the following bearing frames: F16, F18, F18DB, EM16, EM18, EM18DB, VC16, VC18, VC18DB, VF16, VF18, VF18DB.

- External hydraulic balance line
- Back pullout design
- Replaceable hub & suction wear rings
- Replaceable shaft sleeve
- High efficiency hydraulics
- Low operating costs
- Modular bearing frame
- Long B-10 Bearing Life (20,000 hour minimum)
- Two year warranty
- Optional Cycloseal® with type 1 mechanical seal
- Optional Run-Dry™ lubrication system
- Grease lubrication standard - oil lubrication optional
- SAE #1, 2, 3 engine mount available to fit
- Oversized shaft and bearings
- Double volute

PARTS	STANDARD MATERIAL (BRONZE FITTED)
WEAR RINGS	BRONZE SAE 660
IMPELLER	CAST IRON ASTM A48 CL30
VOLUTE	CAST IRON ASTM A48 CL30
SHAFT	SAE 1144 "STRESSPROOF" STEEL
SHAFT SLEEVE	BRONZE SAE 660
SUCTION SPOOL	CAST IRON ASTM A48 CL30
BACKPLATE	CAST IRON ASTM A48 CL30
PACKING (STANDARD)	GRAPHITED ACRYLIC
MECHANICAL SEAL (OPTIONAL)	T-1, BUNA, CARBON/CERAMIC



AGRICULTURE



FOOD



INDUSTRIAL



MINING



MUNICIPAL



OIL & GAS



REFRIGERATION



RENTAL

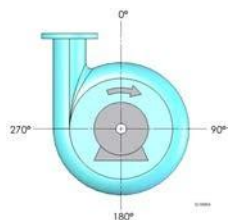

NOTES:

Discharge positions are viewed from the drive end.
Standard increments of discharge position are shown in the chart below (DISCH INCR). Consult factory for other discharge positions.

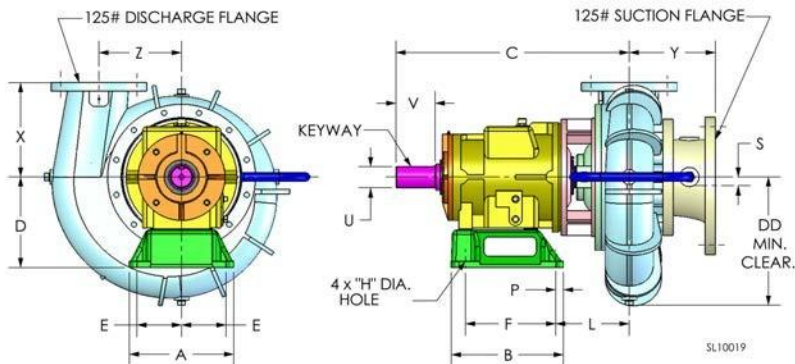

NOTES:

PUMP DIMENSIONS																				
MODEL	FRAME	CONNECTION		DISCH. INC.	A	B	C	D	DD	E	F	H	L	P	U	V	X	Y	Z	KEYWAY
		DISCH.	SUCT.																	
10RB	F18	10	10	90°	12	12.88	30.7	10.5	19.12	5.12	10.38	0.81	12.34	0.88	2.5	4.5	14	10.55	12	.62X.31

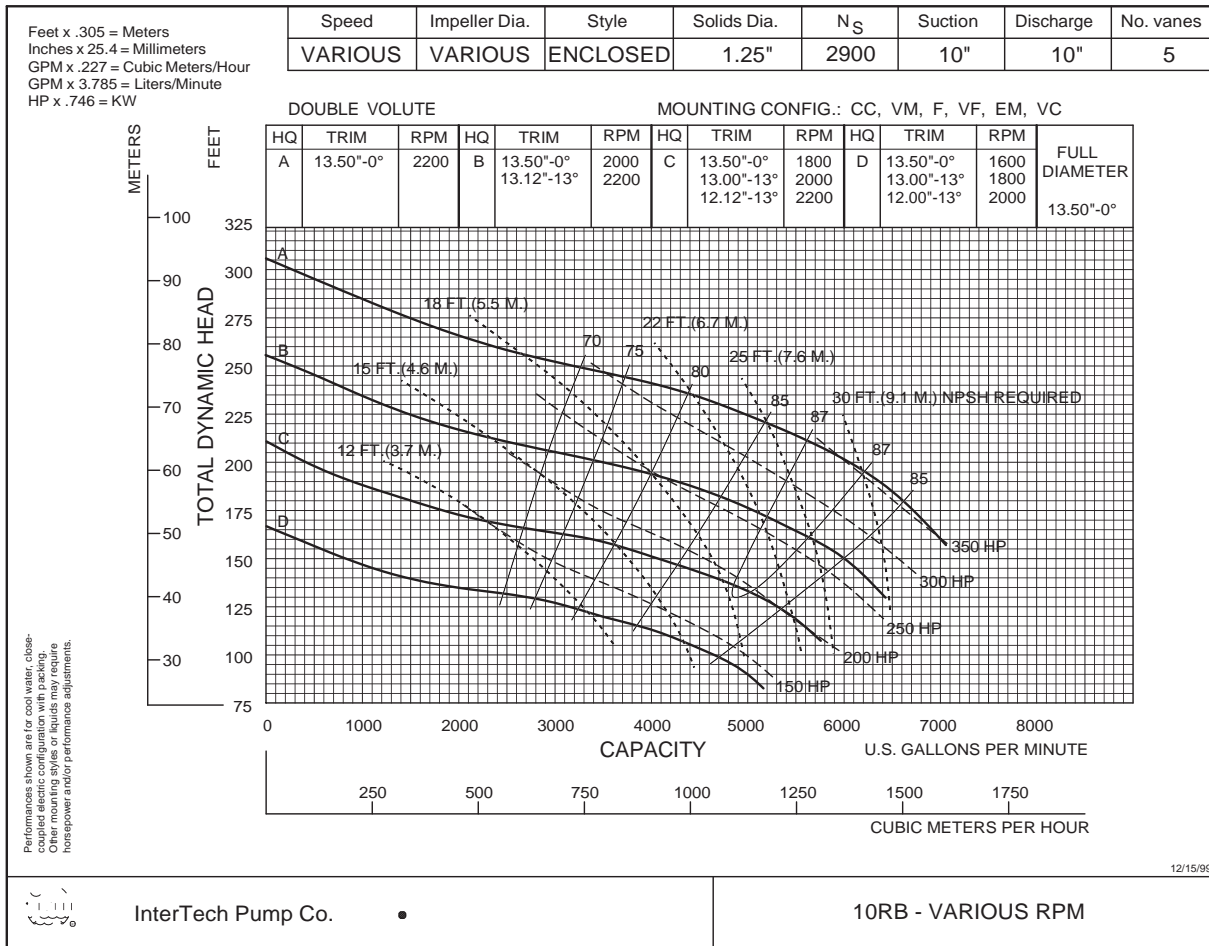

NEW PAGE

10RBVA



InterTech Pump Co.

10RB - VARIOUS RPM